

SPARE PARTS CATALOGUE
: HUSQVARNA PG 280

Spare Parts List

SPARE PARTS LIST

A PG 280
Motor 1-Phase

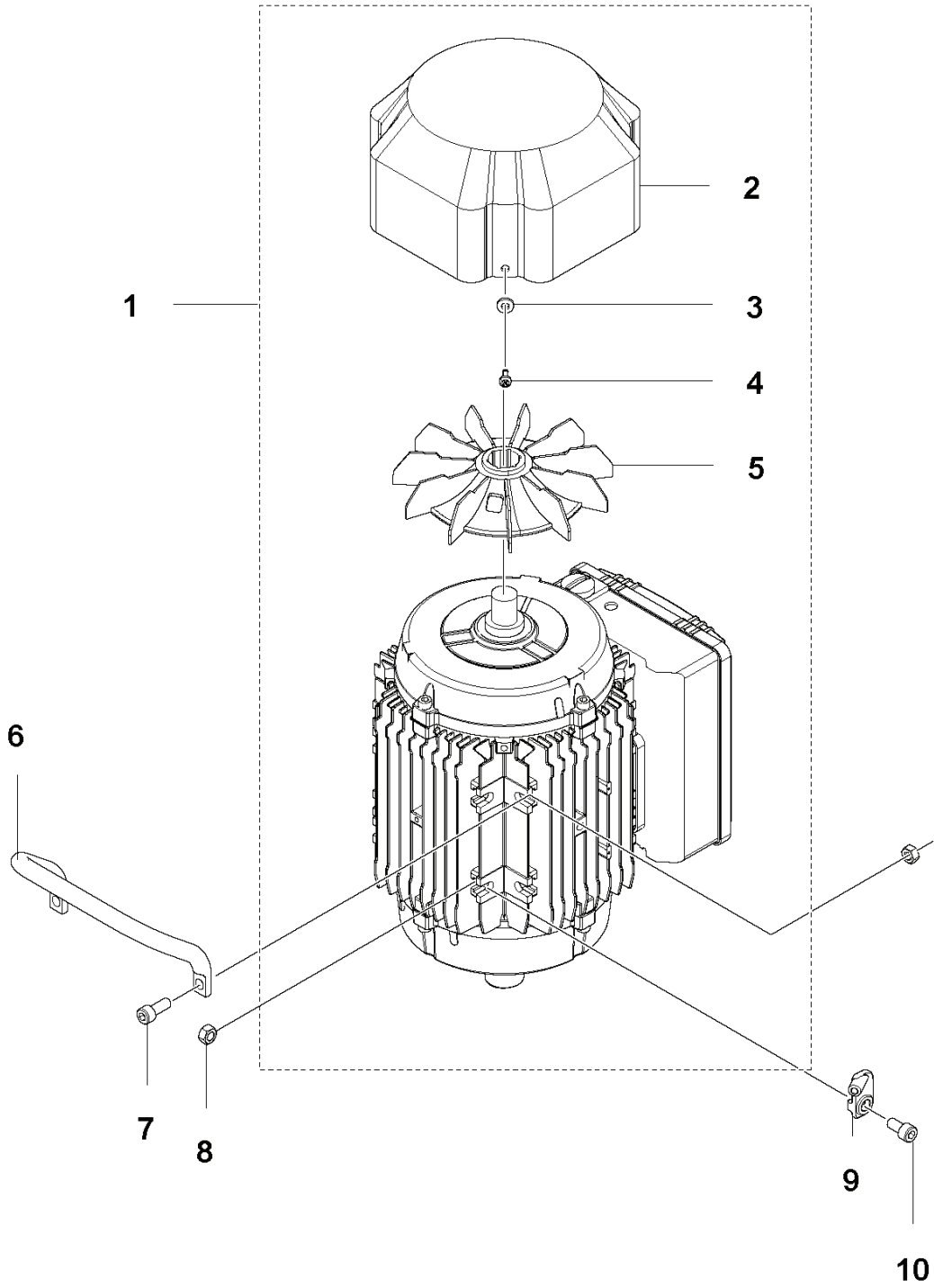

PXM_REF	PXM_PARTNO	DESCRIPTION	PXM_REMARK	QTY.
1	585302102	MOTOR	100-120V, 60 Hz	1
1	585301902	MOTOR	220-240V, 60 Hz	1
1	585301901	MOTOR	220-240V, 50 Hz	1
1	538946801	MOTOR	220-240V, 50 Hz	1
2	587174601	FAN COVER		1
3	734114601	WASHER		4
4	724132301	SCREW CRPANM		4
5	587174701	FAN		1
6	585423303	HANDLE		1
7	725545301	SCREW IHSCM		2
8	731231801	HEXAGON NUT		4
9	588133801	BRACKET		1
10	725545101	SCREW IHSCM		2

B PG 280
Grinding Head

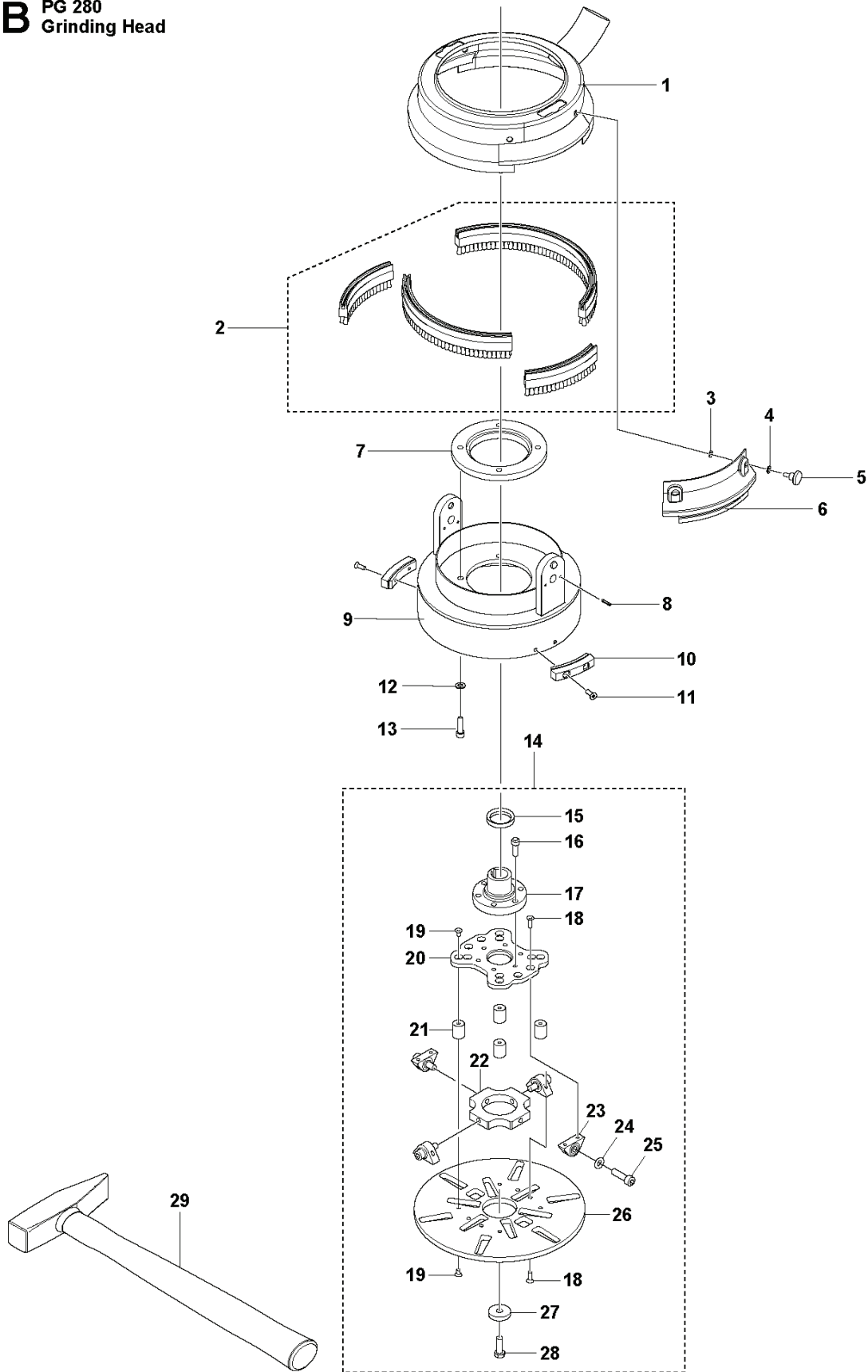

PXM_REF	PXM_PARTNO	DESCRIPTION	PXM_REMARK	QTY.
1	585138701	COVER		1
2	582639901	BRUSH KIT		1
3	735583501	WASHER		4
4	734115260	WASHER		4
5	510361603	SCREW		4
6	586999301	COVER		1
7	585524402	SPACER		1
8	721125930	GROOVED PIN		4
9	585128302	MOUNTING PLATE	HDX variant only	1
9	585128301	MOUNTING PLATE		1
10	585411101	BRACKET		2
11	725636901	SCREW IHCSFM		4
12	734116301	WASHER		4
13	734116301	WASHER		4
14	597768801	GRINDING DISC		1
15	589925801	V-RING		1
16	725545301	SCREW IHSCM		6
17	594895401	COUPLER		1
18	725637051	SCREW IHCSFM		8
19	725636651	SCREW IHCSFM		8
20	597751101	PLATE		1
21	584816101	ABSORBER		4
22	594895001	PLATE		1
23	584816401	CONNECTION		4
24	734117201	WASHER		4
25	725549701	SCREW IHSCM		4
26	598502101	TOOL HOLDER		1
27	510235101	WASHER		1
28	725249571	SCREW EHHM		1
29	522039701	HAMMER		1

C PG 280
Chassi

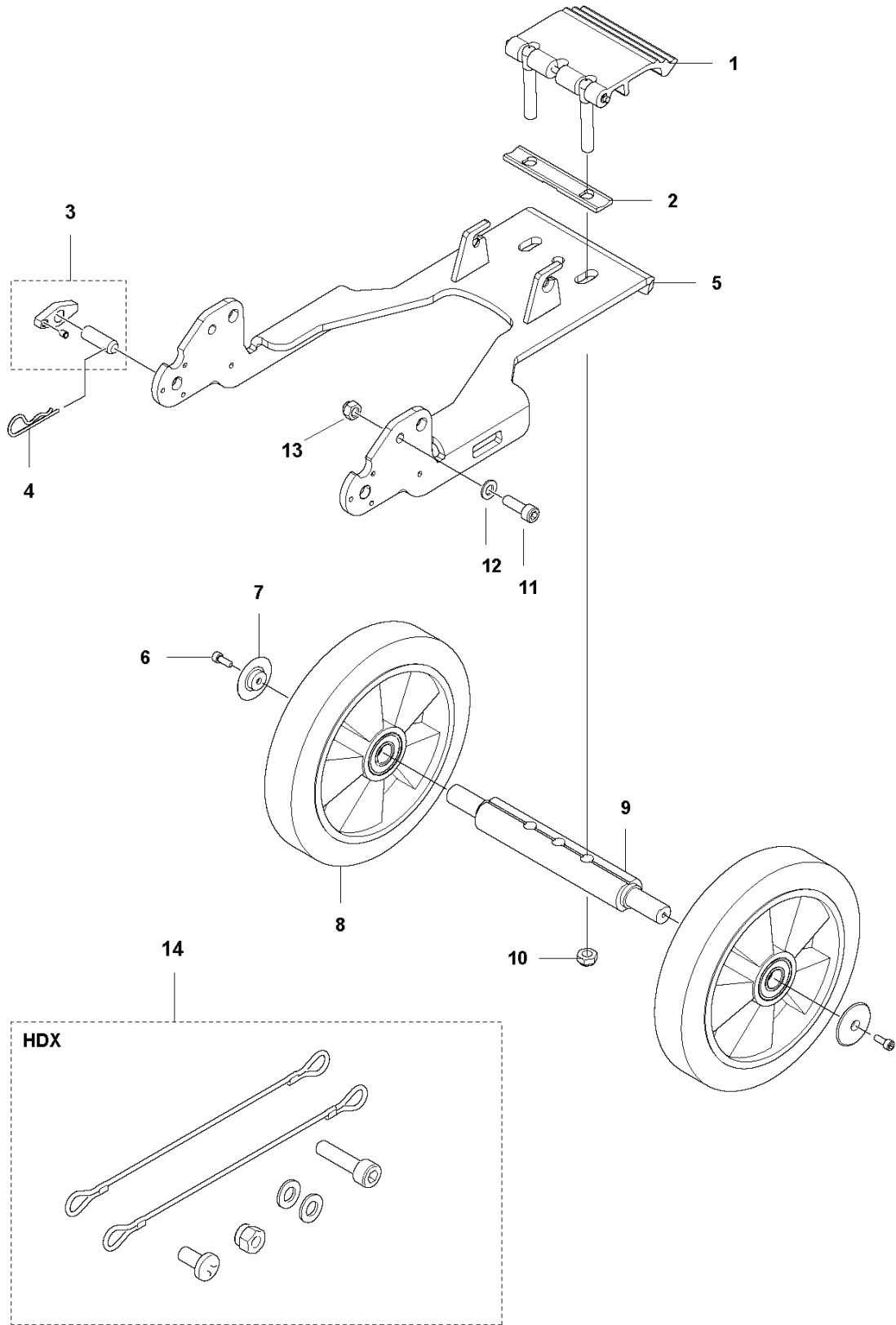

PXM_REF	PXM_PARTNO	DESCRIPTION	PXM_REMARK	QTY.
1	587032901	PEDAL ASSY		1
2	586927501	WASHER		1
3	586991703	BOLT	HDX variant only	2
3	586991701	BOLT		2
4	721680251	SPRING COTTER		2
5	585140502	FRAME		2
6	725536851	SCREW IHSCM		2
7	501321201	WASHER		2
8	504185501	WHEEL		2
9	585141201	AXLE		1
10	732252201	HEXAGON LOCKING NUT		2
11	725549501	SCREW IHSCM		2
12	734117201	WASHER		2
13	732252001	HEXAGON LOCKING NUT		2
14	590540002	WIRE	HDX variant only	1

D PG 280
Frame

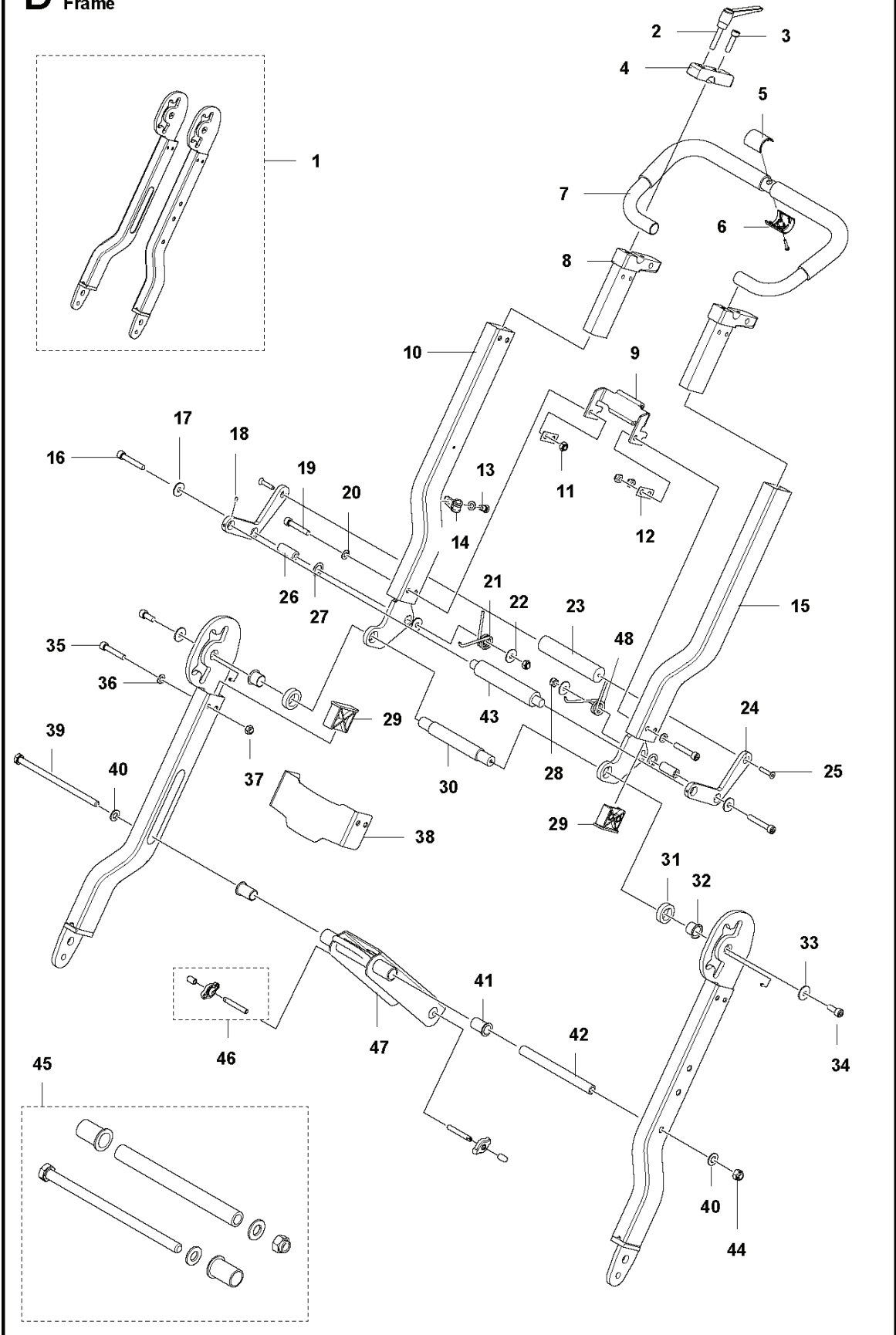

PXM_REF	PXM_PARTNO	DESCRIPTION	PXM_REMARK	QTY.
1	593897101	FRAME TUBE		1
2	585129201	LOCKING HANDLE		2
3	725545521	SCREW IHSCM		2
4	585516601	BRACKET		2
5	587158501	COVER		1
6	587158601	COVER		1
7	585144001	HANDLE		1
8	589837701	BRACKET		2
9	585382802	BRACKET		1
10	585573507	FORK		1
11	732211801	LOCK NUT		8
12	585383101	WASHER		2
13	725536801	SCREW IHSCM		1
14	589669101	CLIP	AUS/US/BR 230V	1
14	589669102	CLIP		1
14	589669103	CLIP	US 100-120V	1
15	585573508	FORK		1
16	725546001	SCREW IHSCM		8
17	734116301	WASHER		8
18	728828501	SCREW IHSETM		6
19	725546101	SCREW IHSCM		2
20	734116441	WASHER		4
21	585417301	SPRING		1
22	734116541	WASHER		4
23	585133702	HANDLE		1
24	585133301	PLATE		2
25	725637451	SCREW		2
26	585383302	SLEEVE		2
27	585416201	WASHER		2
28	732211801	LOCK NUT		2
29	585132901	SPACER		4
30	585133602	TUBE		1
31	585133501	SPACER		2
32	585416001	BUSH		2
33	734116541	WASHER		2
34	732211801	LOCK NUT		2
35	725546001	SCREW IHSCM		8
36	734116301	WASHER		8
37	732251801	HEXAGON LOCKING NUT		10
38	585383004	BRACKET	HDX variant only	1
38	585383002	BRACKET		1
39	590105001	BOLT		1
40	734117201	WASHER		2
41	585129101	BUSH		2
42	590092901	PIPE		1
43	585133802	ROD		1
44	732252001	HEXAGON LOCKING NUT		1
45	593909401	CROSSBAR		1
46	590472201	WING KNOB		2
47	585141802	SUPPORT		1
48	585416101	SPRING		1

E PG 280
Electrical

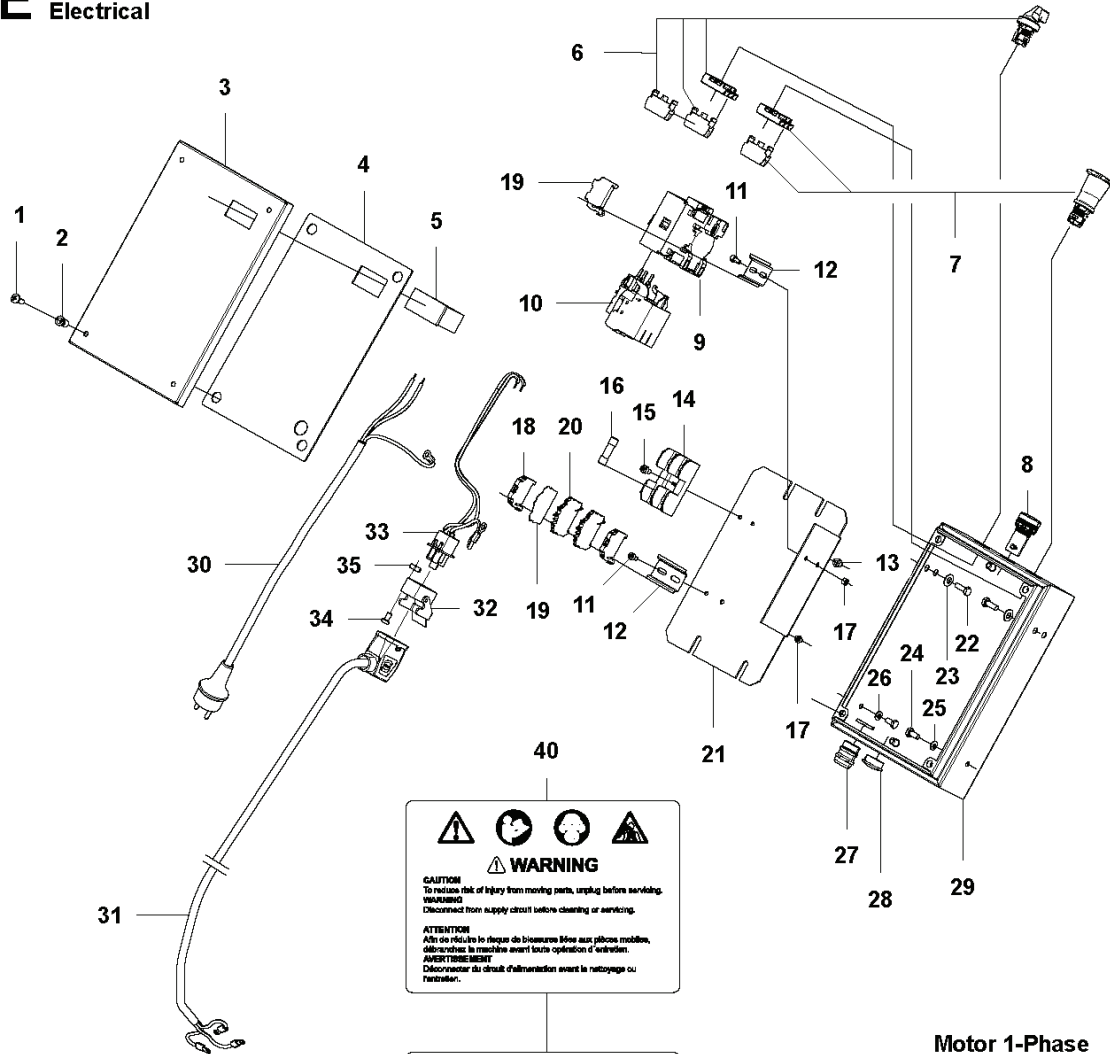

⚠ ⚠ ⚠ ⚠
⚠ WARNING
CAUTION
 To reduce risk of injury from moving parts, unplug before servicing.
NEVER
 Disconnect from supply circuit before cleaning or servicing.

ATTENTION
 Afin de réduire le risque de blessures liées aux pièces mobiles,
 débranchez le matériel avant toute opération d'entretien.
AVERTISSEMENT
 Déconnecter du circuit d'alimentation avant le nettoyage ou
 l'entretien.

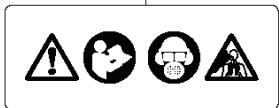

Motor 1-Phase

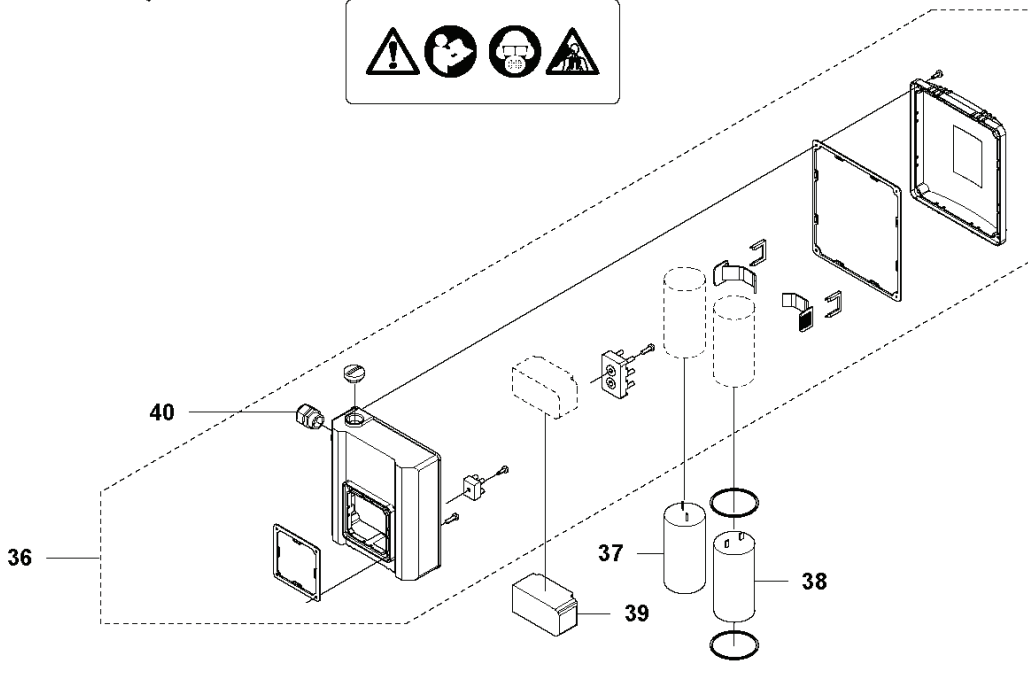

PXM_REF	PXM_PARTNO	DESCRIPTION	PXM_REMARK	QTY.
1	724136851	SCREW CRPANM		4
2	521886601	RIVET		4
3	586474303	LID	HDX variant only	1
3	586474301	LID		1
4	586467002	SEALING		1
5	584296301	HOUR METER		1
6	586991501	SWITCH KIT		1
7	586991601	SWITCH KIT		1
8	584297101	LAMP	230V	1
8	584297102	LAMP	110V	1
9	585365801	CONTACTOR	200-230V, 50/60Hz	1
9	585365802	CONTACTOR	100-120V, 60Hz	1
9	586991801	CONTACTOR	100-120V, 50Hz	1
10	584297801	RELAY	1 phase, 220-240V, 50Hz	1
10	580623501	PROTECTION	1 phase, 100-120V, 50Hz	1
10	580623502	PROTECTION	1 phase, 220-240V, 60Hz	1
11	725532501	SCREW IHSCM		4
12	522747001	RAIL		2
13	731231601	HEXAGON NUT		1
14	525882601	FUSE HOLDER		1
15	725536455	SCREW IHSCM		1
16	525638101	FUSE		2
17	732251401	HEXAGON LOCKING NUT		4
18	585366105	TERMINAL BLOCK		3
19	585366103	TERMINAL BLOCK		1
19	585366107	TERMINAL BLOCK	US 1ph 100-120V	1
20	585366101	TERMINAL BLOCK	US 1ph 100-120V	2
20	585613501	TERMINAL BLOCK		2
21	590075801	MOUNTING PLATE		1
22	725245171	SCREW EHHM		4
23	734116301	WASHER		4
24	725236651	HEXAGONAL SCREW M6X12		2
25	734115201	WASHER		1
26	735215301	LOCKWASHER		4
27	575489801	GROMMET		1
27	587101201	GROMMET	US 1ph 100-120V	1
28	587101201	GROMMET	US 1ph 100-120V	1
28	586586901	PLUG		1
29	582506904	ELECTRONIC BOX	HDX variant only	1
29	582506903	ELECTRONIC BOX		1
30	586236802	CABLE	AUS	1
30	586236803	CABLE		1
30	586236813	CABLE	US 240V	1
30	586236808	CABLE	BR	1
30	586236812	CABLE	US 120V	1
31	585638111	CABLE	US/CAN 100-120V	1
31	585638108	CABLE	UK and JP	1
31	585638110	CABLE	US/CAN 220-240V	1
32	585366605	CONNECTOR		1
33	590503501	CONNECTOR		1
34	725522401	SCREW		2
35	732251001	HEXAGON LOCKING NUT		2
36	587173901	ELECTRONIC BOX	1-ph	1
36	587173902	ELECTRONIC BOX	3-ph	1
37	587174502	CAPACITOR	110V, 50Hz	1
37	587174501	CAPACITOR	208-230V, 50/60Hz	1
38	587174401	CAPACITOR	230V, 50Hz	1
38	587174402	CAPACITOR	208-230V, 60Hz	1
38	587174403	CAPACITOR	110V, 50/60Hz	1
39	587174301	SWITCH	230V, 50Hz	1
39	587174302	SWITCH	208-230V, 60Hz	1
39	587174303	SWITCH	110V, 50/60Hz	1
40	590518301	DECAL	US/CAN only	1
40	590518401	DECAL	ROW	1